

RRHX rising stem elastic seat seal gate valve

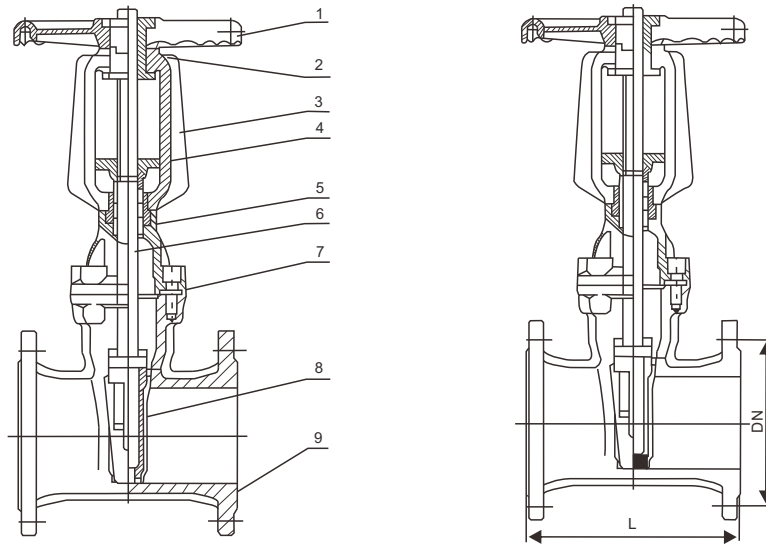

Product overview

RRHX(Z41X) flexible stem seat soft seal gate valve is composed of valve body, cover, stem, stem nut, gate and other parts. The valve uses the elastic gate to produce trace elastic deformation compensation effect to achieve good sealing effect, the valve has a light switch, Reliable sealing, good elastic memory and long service life and other significant advantages, using full diameter, dark rod operation, flange bolt connection, Flat bottom seat, no debris settling. Can be widely used in tap water, sewage, construction, petroleum, chemical, food, medicine, Used as regulating and closing device in light textile, electric power, shipbuilding, metallurgy and energy system pipelines.

Main technical parameters

Nominal pressure	Nominal diameter	Working temperature	Applicable medium	The standard of the flange	Test standard
1.0~2.5MPa	50~400mm	0~80°C	Water, oil, gas, etc	GB/T17241.6 GB9113	Gb13927 API598

Main components and materials

NO.	Part name	material
1	The handwheel	Stainless steel
2	Stem nut	Stainless steel
3	stents	Stainless steel
4	gland	Stainless steel
5	Sealing ring	Nitrile butadiene rubber, epDM
6	The valve stem	Stainless steel
7	In the mouth mat	Nitrile butadiene rubber, epDM
8	ram	Stainless steel + EPDM or NBR
9	The lock body	Stainless steel

Main connection size

Unit: mm

Nominal diameter	L	seated	Fully open
50	178	322	374
65	190	332	398
80	203	350	429
100	229	420	524
125	254	581	721
150	267	581	736
200	292	736	942
250	330	882	1013
300	356	1009	1117
350	381	1300	1655
400	406	1380	1805

Transmission mode: manual, electric, pneumatic, hydraulic.